



Similar Image



Throttling J-Lock valve, RS-232 controller

HV throttling butterfly valve, DN 50 KF, QP controller,
partially sealing, 24 VDC, SS

Part number: TBJQPNN-L051

Throttling J-Lock valve, RS-232 controller
HV throttling butterfly valve, DN 50 KF, QP controller, partially sealing, 24 VDC, SS

- Adaptive algorithm for improved stability and faster transitions
- Space saving, low cost design
- High reliability, low particle generation
- Can be operated in any orientation
- Body can be heated up to 200°C with optional heaters
- CE marked/fully REACH and RoHS compliant



Similar Image

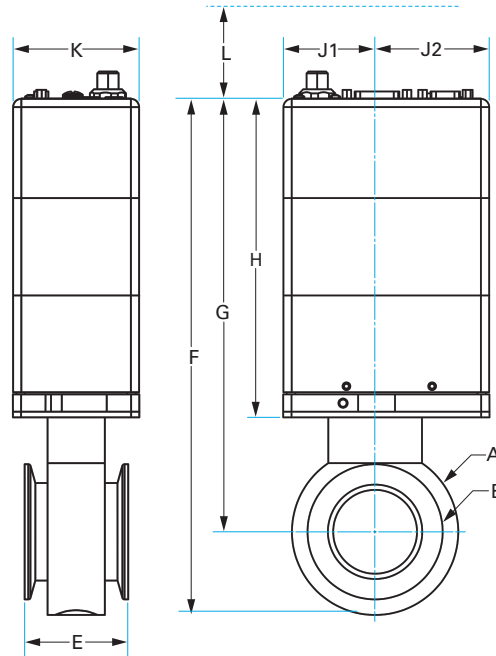

Dimensions <i>(in inches)</i>	
Dim A	3.62"
Dim B	2.95"
Dim E	2.25"
Dim F	11.3"
Dim G	9.45"
Dim H	6.97"
Dim J-1	2.01"
Dim J-2	2.48"
Dim K	2.76"

TBJQPNN-L051

Parameters	Specifications
Valve / Flange Size	DN 50 ISO-KF
Communications Interface	RS232
Additional Controller Features	none
Flange Size / Type	DN 50 ISO-KF
Controller Communications	RS232 system interface; RS232 service port
Supply Voltage	24 V DC (±5 %)
Power Connector	XLR, 5-pin, Female
Gauge Power Supply	not included
Pressure Range	1 · 10 ⁻⁸ mbar to 1.1 bar
Max Differential at Opening	1100 mbar
Max Temp (body)	150 °C

Throttling J-Lock valve, RS-232 controller
 HV throttling butterfly valve, DN 50 KF, QP controller, partially sealing, 24 VDC, SS

TBJQPNN-L051

Parameters <i>(Continued)</i>	Specifications <i>(Continued)</i>
Temp. Limits (actuator)	5 °C (minimum), 45 °C (maximum)
Open / Close Time	625 ms/625 ms
Open Conductance	150 l/s
Min. Control Conductance	0.3 l/s
Material (valve body)	316L Stainless Steel
Material (valve mechanism)	316L Stainless Steel
Plate Seal	PTFE
Shaft Seal	FKM
Leak Rate (body)	1 · 10 ⁻⁹ mbar l/s
Service Life	5 million cycles
Weight	8.14 lbs

VACUUM SOLUTIONS FOR INDUSTRY & RESEARCH

Nor-Cal Products is a premier global source for custom and standard high and ultra-high vacuum chambers and components critical to the success of industrial, semiconductor, coating, analytics, and research applications. We offer an extensive selection of vacuum line fittings, hardware, valves and components which complement our custom manufacturing capabilities.

EARNING YOUR TRUST

Innovative engineering, precision manufacturing, exceptional service and expert technical support are cornerstones of our corporate culture and continuous improvement goals. Your trust is our most important asset.

INNOVATION SINCE 1962

An added value to working with Nor-Cal Products is how we apply our vacuum science and industry expertise to your production and research goals and timelines. We continue to develop new component lines and services to serve the demands of the exciting and ever emerging applications that require vacuum components.

Nor-Cal Products
Headquarters: USA
1-800-824-4166 or 530-842-4457
ncsales@n-c.com
www.n-c.com



RoHS2/REACH compliant
Conflict mineral regulations enforced

All data subject to change without prior notice.

